

PENDULOS (U-BOLTS)

Modelo (Model)	Dimensiones (Dimensions) mm			Carga min. de rotura Min. breaking strength kN
	A	B	ØD	
PU-1	80	220	16	90
PU-2	80	240	16	90
PU-3	100	240	16	90
PU-4	80	240	19	120
PU-5	100	240	19	120
PU-6	80	270	19	120
PU-7	100	270	16	90

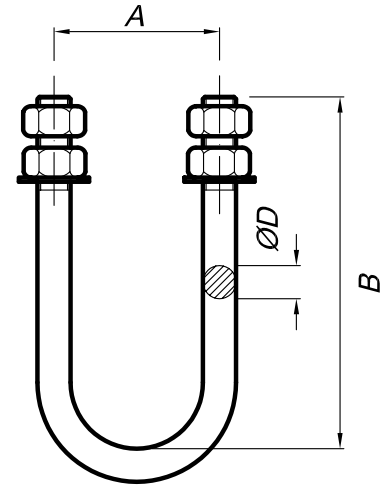

ESTRIBOS (V-SHACKLES)

Modelo (Model)	Dimensiones (Dimensions) mm						Carga min. de rotura Min. breaking strength kN
	A	B	ØD	ØE	C	Fig.	
EC-1	140	135	16	16	90	1	80
EC-2	140	140	19	19	90	1	100
EC-4	248	135	16	16	170	1	80
EC-5	248	140	19	19	170	1	100
PV-1	150	100	16	16	60	2	100
PV-2	150	100	19	19	60	2	120

Fig. 1

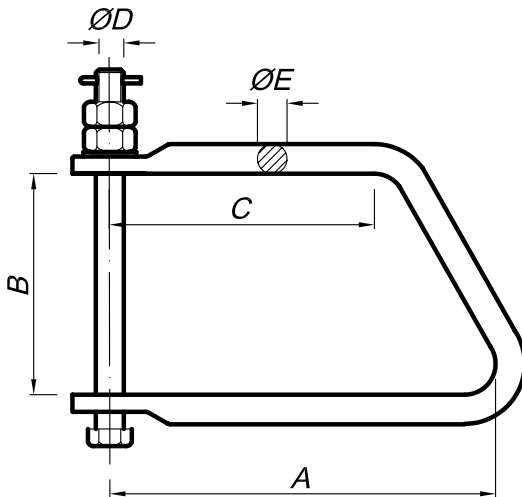

Fig. 2

