

SISTEMA DE CONTRAPESO (SYSTEM OF COUNTERWEIGHT)

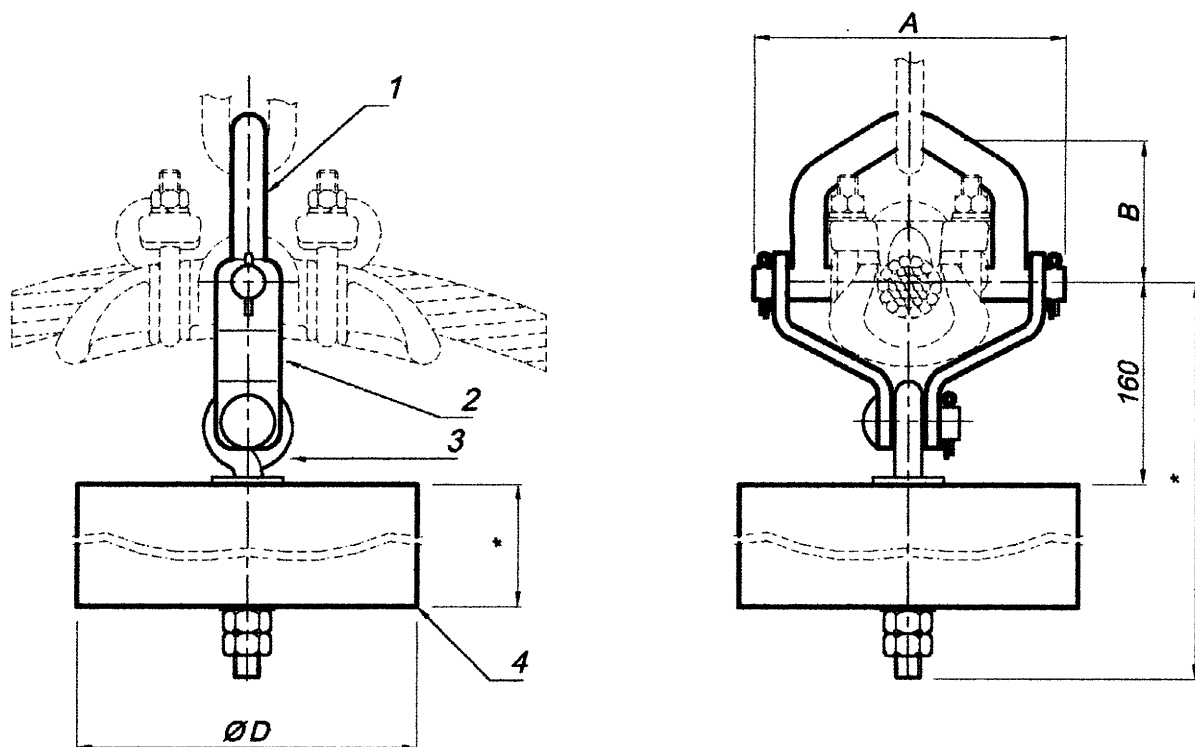

Carga mínima de rotura: 10 kN
(Min. breaking strength: 10 kN)

Morsa (Clamp)	A	B	ØD	
			Ac.	Pb.
MAS-2C	145	70	290	200
MAS-3C	175	90	290	200

*: Funcion del peso
(Function of the weight)

IDENTIFICACION (IDENTIFICATION)

Pieza (Piece)	Denominacion (Denomination)	Material (Material)
1	Enganche (Hook)	Ac.SAE 1010 (Steel SAE 1010)
2	Placa (Plaque)	Ac.SAE 1010 (Steel SAE 1010)
3	Tilla (Bolts ovaleye)	Ac.SAE 1010 (Steel SAE 1010)
4	Contrapeso (Counterweight)	Ac.SAE 1010 o Pb. (Steel SAE 1010 or Pb.)